

RAIL BULL 2

MODULAR TRACK WELDING TRACTOR FOR ALL-POSITION MECHANIZED WELDING AND CUTTING

Primary features and benefits:

- Fully modular mechanized travel carriage can be custom configured for a variety of welding, thermal cutting and gouging applications on flat or curved plate, tube and pipe
- Linear torch oscillator to produce weave welds
- Active compensation of torch position vertically and horizontally by means of modular automatic seam tracking system
- Programmable path of stitch welds
- Possibility to select one limit switch preset out of three presets available.
- Suitable for variety of circumferential and irregular surface applications down to minimum radius of 100 mm (4")
 - Ring tracks on diameters from 200 mm (8") OD up to 3 m (10 ft) OD
 - Custom rolled tracks on diameters from 3 m (10 ft) OD up to 10 m (32 ft) OD
 - Semi-flexible tracks can be flexed to minimum radius of 5 m (16 ft) without permanent deformation
- Ergonomic remote control pendant with simple and easy to find control knobs makes adjustments possible without lifting of the operators welding hood
- Magnetic adhesion of the pendant provides firm grip on ferromagnetic materials
- Suitable for all welding positions on both ferromagnetic and non-ferromagnetic materials thanks to rack and pinion drive and various tracks equipped with magnetic or vacuum units
- Rail Bull 2 produces consistent high quality welds and cuts in a fraction of the time required by manual operations
- High speed up to 3 m/min makes plasma cutting available



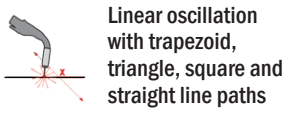

Linear oscillation with trapezoid, triangle, square and straight line paths



Ring tracks from 200 mm (8") OD up to 3 m (10 ft) OD



Custom rolled tracks from 3 m (10 ft) OD up to 10 m (32 ft) OD



Min. path convex radius for semi-flexible tracks is 5 m (16 ft)



Continuous welding



Stitch welding



Horizontal speed 10-300 cm/min



Vertical speed 10-300 cm/min

Rail Bull 2 can work in all welding positions on both ferromagnetic and non-ferromagnetic materials by using rack and pinion drive and various tracks equipped with magnetic or vacuum units.

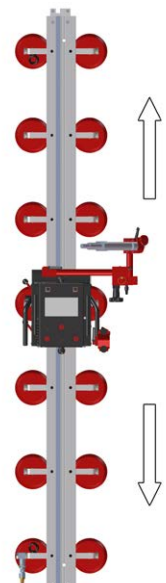
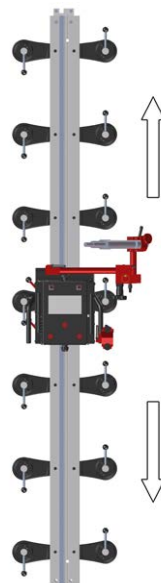
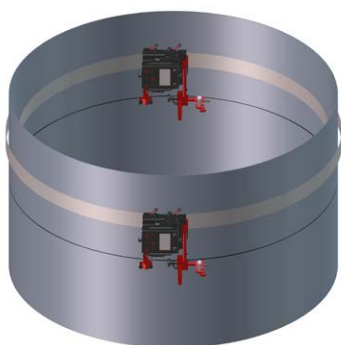
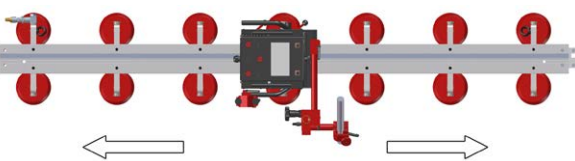
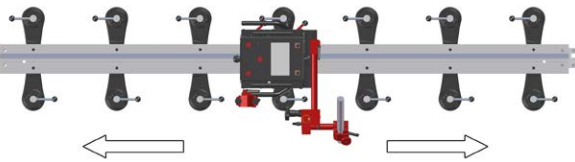
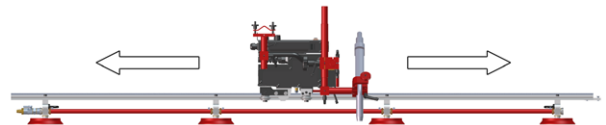
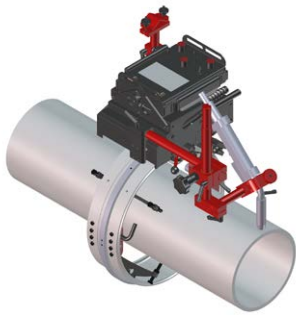

Features and benefits:

- Easy to upgrade modular design
- Continuous and programmable path of stitch welds (weld length, space between welds, backweld length, crater fill time)
- Linear torch oscillator to produce weave welds
- Three modes of automatic seam tracking (vertical, horizontal and both)
- Limit switch stops the arc and travels the tractor to the initial position
- Hand-held ergonomic control pendant (3 m cable included) with magnetic adhesion provides firm grip on ferromagnetic materials
- Multifunctional LED display with numeric representations for each motion parameter makes presetting and repeating of the optimum welding or cutting procedure simple and without guess work
- Intuitive software with user-friendly interface
- Automatic arc on/off initiates welding and travel simultaneously
- Rack and pinion drive
- Convenient external 230 V, 115 V or 42 V power supply
- Closed-loop position control system based on electric motor with encoder – ensures increased accuracy of speed and position
- Consistent heat input reduces distortion
- Reduces wasted filler metal – eliminates over welding
- Quick-clamping torch holder mechanism for different types of torches with diameters of 16–22 mm (0.63–0.87”); up to 35 mm (1.38”) option
- Precise torch adjustment
- Improves working environment – removes operator from heat and fumes

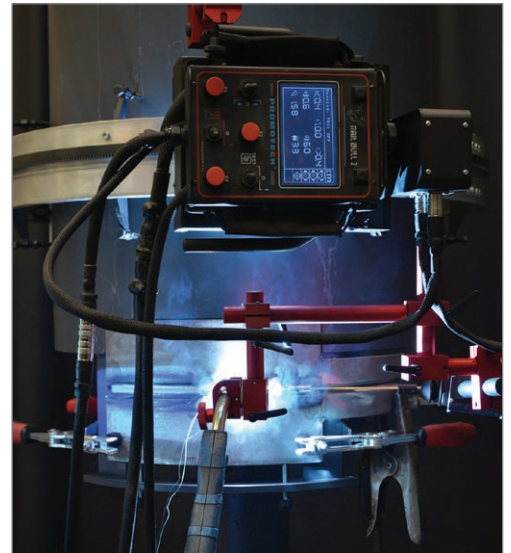
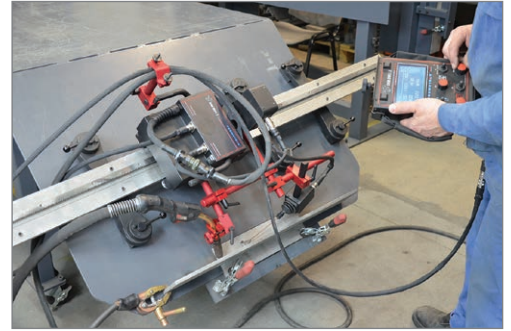

RAIL BULL 2 Technical specification		
Voltage		1~230 V, 50–60 Hz 1~115 V, 50–60 Hz 1~ 42 V, 50–60 Hz
Power		120 W
Welding position (according to EN ISO 6947 and AWS/ASME)		PA / 1F / 1G PB / 2F PC / 2G PD / 4F PE / 4G
		PF / 3G PG / 3F (contact your dealer) PG / 3G
Fixing on pipes and round workpieces	Ring tracks	from 200 mm (8") OD up to 3 m (10ft) OD
	Custom rolled tracks	from 3 m (10 ft) OD up to 10 m (32 ft) OD
	Semi-flexible track	Minimum curvature radius of 5 m (16 ft)
Torch type		MIG/MAG, TIG, Plasma, Oxy-fuel
Torch diameter		16–22 mm (0.63–0.87") up to 35 mm (1.38") option
Horizontal pulling force		400 N
Vertical pulling force		300 N
Horizontal speed		0–300 cm/min (0–120 in/min)
Vertical speed		0–300 cm/min (0–120 in/min)
Oscillation type		Linear
Weld path		Straight, triangle, trapezoid, square
Oscillation width		0.2–11.8 cm (0.1–4.5")
Oscillation speed		10–300 cm/min (5–120 in/min)
Oscillation dwell time at center and on ends		0–5 s
Weight		10 kg (22 lbs)

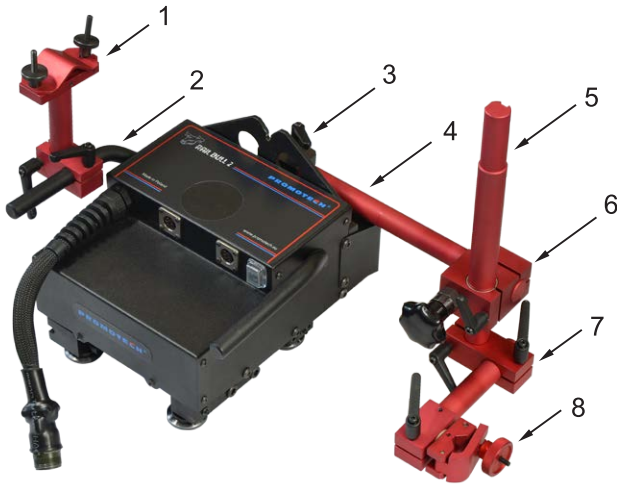

1. Cable anchor
2. Carrying handle
3. Torch rod holder
4. 300 mm (12") rod
5. 300 mm (12") rack with 180 mm (7") adjustment range
6. Rackholder
7. Clamping block with levers
8. Short rod torch holder with fits-all clamp

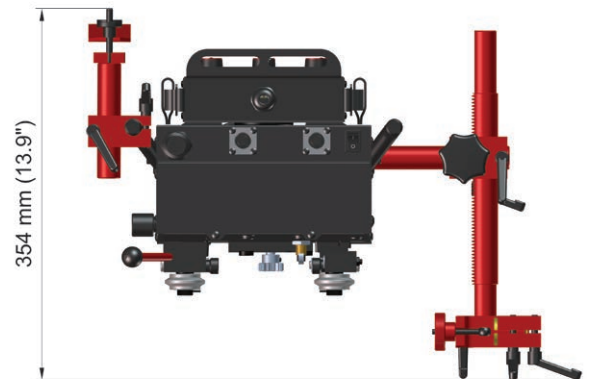

Weld paths:

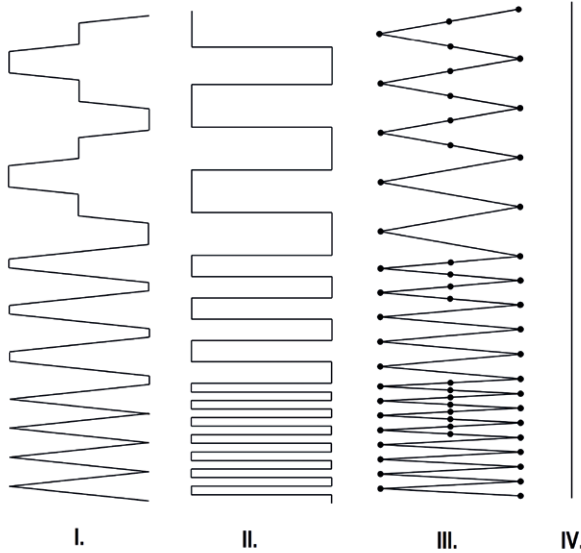

- I. Trapezoid The carriage travels continuously even during dwell mode. Weld path is determined by weave speed and dwell time at center and on sides of the weld path.
- II. Square The carriage travels only during dwell and stops during oscillator cross travel. Only dwell time determines the weld path, and weave speed has no influence.
- III. Triangle The carriage travels only during weaving. Both the carriage and oscillation stop during dwell mode.
- IV. Straight The carriage travels continuously while oscillation is switched-off.

Standard accessories:



5 m (17 ft) power cable
PWD-0523-10-03-00-0



Remote control pendant
PNL-0523-03-00-00-0



3 m (10 ft) remote control cable
PWD-0523-10-01-00-0

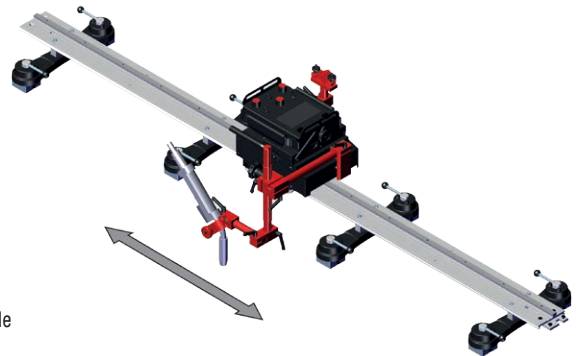

6.5 m (21 ft) arc ignition cable
KBL-0466-17-00-00-0



300 mm (12") rod
WSP-0523-16-00-00-0



Rackholder
ZSP-0475-62-00-00-0



300 mm (12") rack
RAM-0523-17-00-00-0



Cable anchor
UCW-0523-05-01-00-0



Clamping block with levers
KST-0525-11-00-00-0



Short rod torch holder with fits-all clamp
UCW-0476-20-00-00-0



Contact block
ZDR-0523-76-00-00-0

Optional equipment:



Power supply
 (3 voltage versions to choose from)
 1 ~ 230 V, 50-60 Hz, ZSL-0523-09-00-00-0
 1 ~ 115 V, 50-60 Hz, ZSL-0523-09-00-01-0
 1 ~ 42 V, 50-60 Hz, ZSL-0523-97-00-02-0

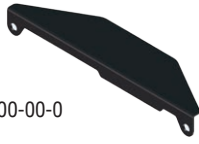

OSL-0526-22-00-00-0
 Display shield

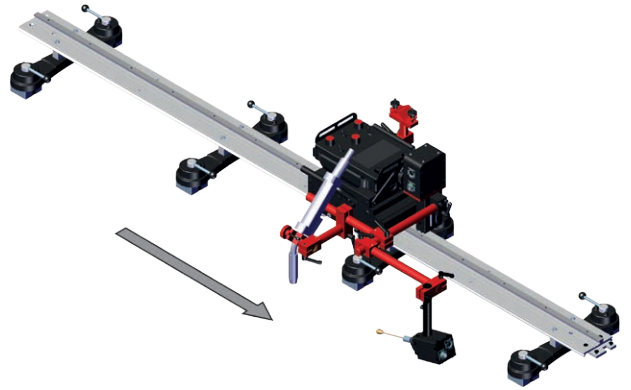

Configuration with seam tracking horizontally and vertically requires an optional seam tracking attachment and a motorized vertical slide

Motorized vertical slide
 OSK-0523-06-00-00-0



Active torch position control
 vertically and horizontally

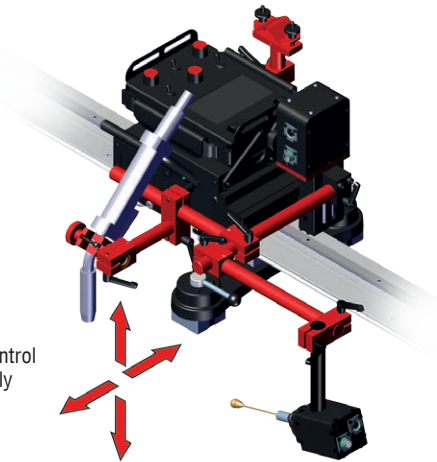

Seam tracking attachment
 CZJ-0523-07-00-00-0



Rod for sensor tips
 WSP-0523-07-01-13-0

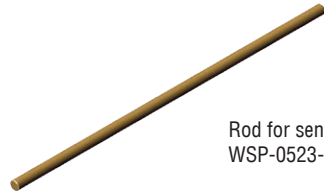

Sensor tip (rod required)
 ADT-0506-43-00-00-0



Sensor tip (rod required)
 ADT-0506-40-00-00-0



Sensor tip (rod required)
 ADT-0506-41-00-00-0

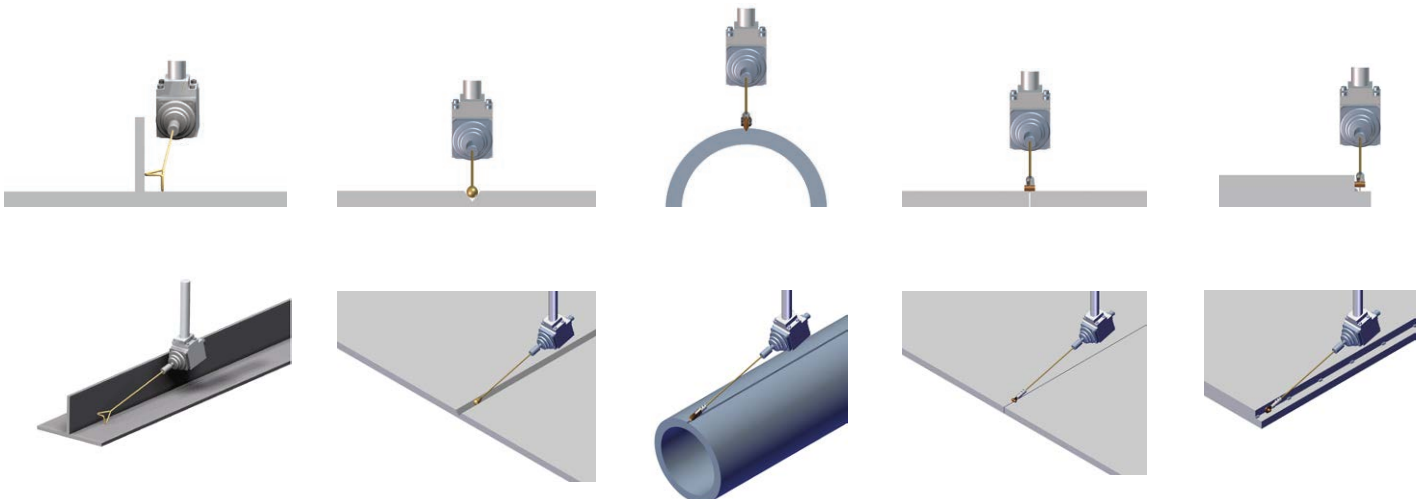

Ring tracks

Available on request, diameter can be custom configured within the range from 200 mm OD up to 3000 mm OD (from 8" to 10 ft).

Ring tracks can be equipped with various supports depending on the customer's needs.



Support with bolts
WSP-0523-14-02-00-0

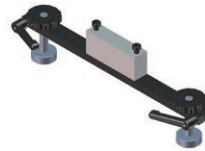

Support with magnets
WSP-0523-14-12-00-0



Support with plastic feet
WSP-0523-14-11-00-0

Rigid track length 2 m (6.5 ft)
PRW-0482-47-00-00-0



Bracket for magnetic unit
for rigid track
DYS-0482-21-00-00-0



Magnetic narrow unit with hexagon
PDS-0582-10-00-02-0

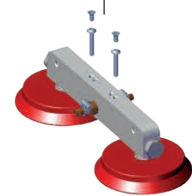

Vacuum modular unit
MST-0541-10-02-00-0



Magnetic unit
ZSP-0475-44-00-00-0

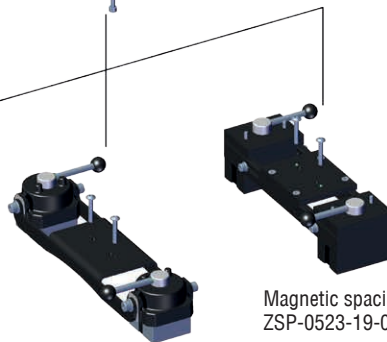

Magnetic pivoting unit
ZSP-0475-85-00-00-0



Magnetic spacing-adjustable unit
ZSP-0523-19-00-00-0

Semi-flexible track length 2 m (6.5 ft)
Minimum 5 m (16 ft) curvature radius required
PRW-0482-15-05-00-0

Semi-flexible tracks can be custom rolled permanently within the radius range from 1.5 m up to 5 m (5 ft up to 16 ft)



Bracket for magnetic unit for
semi-flexible track
DYS-0482-19-00-00-0

Bracket for magnetic
narrow unit for semi-
flexible track
DYS-0582-10-00-00-0

Bracket for magnetic unit for
semi-flexible track
DYS-0482-19-00-00-0

Bracket for vacuum
modular unit for semi-
flexible track
DYS-0541-11-01-00-0

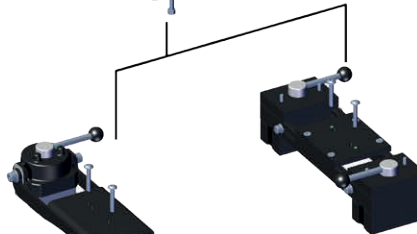

Magnetic spacing-adjustable unit
ZSP-0523-19-00-00-0

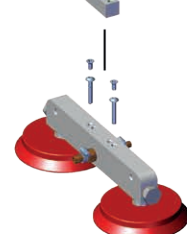

Vacuum modular unit
MST-0541-10-02-00-0

Aluminum track support
for semi-flexible track
WSP-0541-11-02-00-0

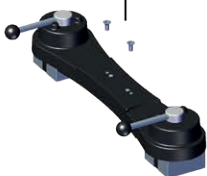

Magnetic unit
ZSP-0475-44-00-00-0

Magnetic narrow unit with hexagon
PDS-0582-10-00-02-0



Steel track support for
semi-flexible track
WSP-0523-12-01-00-1

Magnetic pivoting unit
ZSP-0475-85-00-00-0

Rail Bull 2 is supplied in plastic box including:

- Tractor
- Power supply
- 5 m (17 ft) power cable
- Remote control pendant
- 3 m (10 ft) remote control cable
- 6.5 m (21 ft) arc ignition cable
- 300 mm (12") rod
- 300 mm (12") rack
- Rackholder
- Clamping block with levers
- Short rod torch holder with fits-all clamp
- Cable anchor
- Contact block
- 6 mm hex wrench
- Operator's Manual



Applications:

- Trailer manufacturing
- Truck tanks
- Oil tanks
- Water storage tanks
- Pressure vessels
- Vessel overlay / hardfacing
- Bridge girders
- Structural steel
- Structural towers
- Panel welding
- Transformers
- Shipyards
- Any application demanding long continuous welds

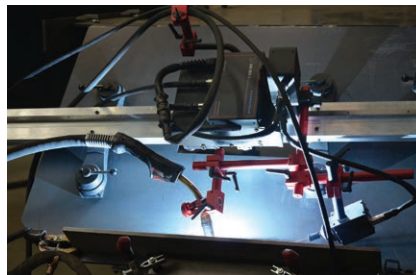

Mitglied im **DVS**
DVS – Deutscher Verband für Schweißen
und verwandte Verfahren e.V.

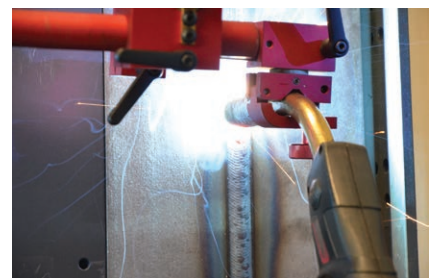

More information available at www.promotech.eu



PROMOTECH Sp. z o.o.
ul. Elewatorska 23/1, 15-620 BIAŁYSTOK, POLAND
tel. (+48 85) 678 34 05, fax (+48 85) 662 78 77
marketing@promotech.eu www.promotech.eu

Your local dealer:

